



ANTENNA MATCHING NETWORKS

BELLBROOK AMATEUR RADIO CLUB TECH NIGHT

JOHN WESTERKAMP, W8LRJ

W8LRJ@ARRL.NET

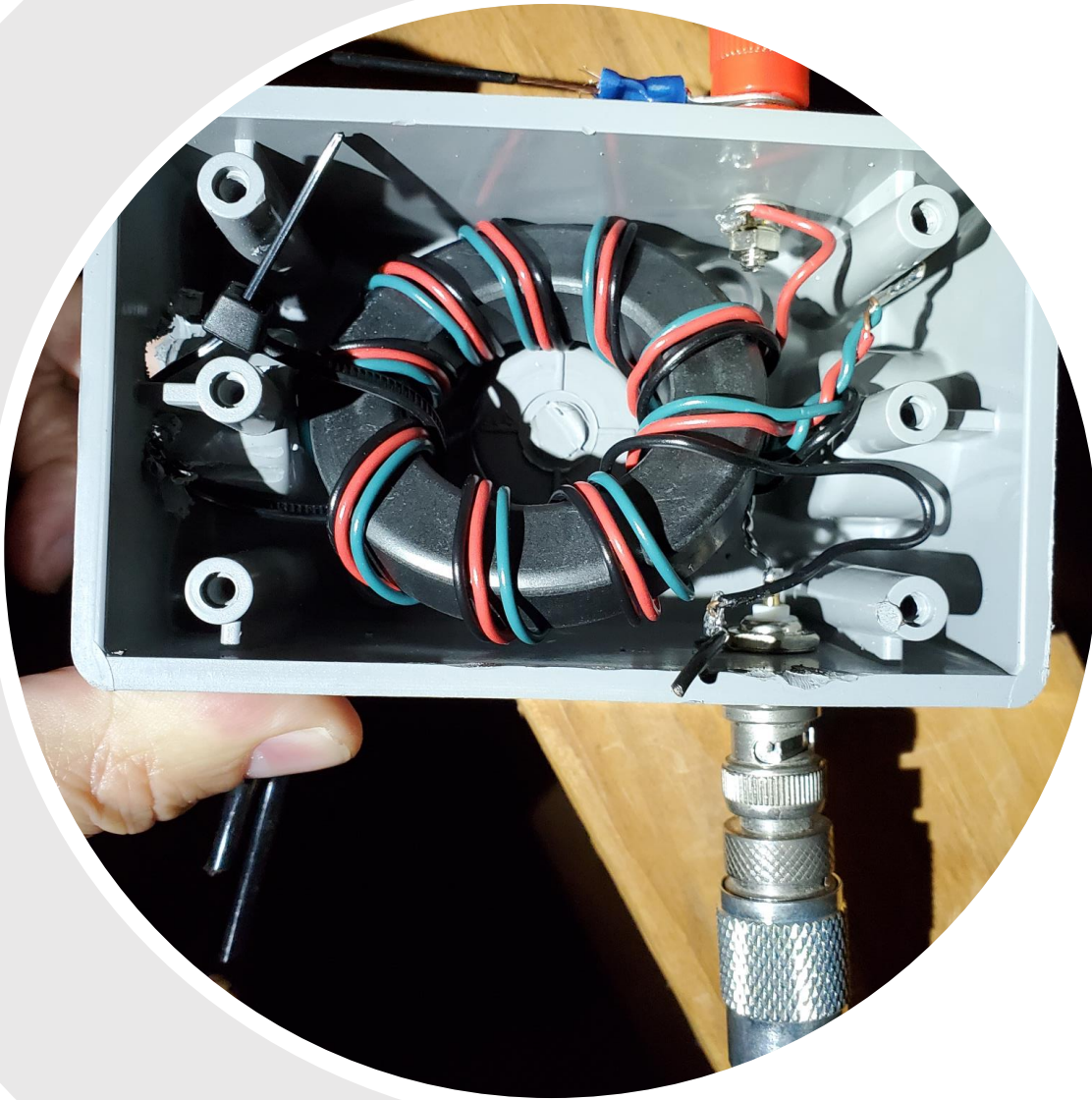

CONTENT

- Background
- Overview of Matching Networks
- The L Network
- L Network Design Using Smith Charts
- Wideband Toroidal Transformers
- End-Fed Halfwave and Random Wire Antennas
- 1:1 Current Choke
- Calculating Choke Impedance
- Design Example for Random Wire Antenna
- Photos
- Building a Toroidal Transformer





BACKGROUND

- I was looking at various antenna designs for my HF rig (Yaesu 897D) mainly for FT-8
- I wanted **something simple that would fit in my attic**
- I could not see paying \$100 for what appeared to be a length of wire and some wound toroids (at least until I understood how they worked)
- I settled on **a random wire antenna about 53 feet long with an impedance transformer (wound toroid) and a choke (to minimize RFI leaking into my shack)**
- I have made contacts all over North and South America, Europe, and parts of Africa and European Russia running 50 watts on FT-8
- Works great on **17, 20, 30, and 40 meters (tuner gets SWR < 1.2)**
- Also works on 80 meters (SWR about 1.75)
- Looking forward to moving the antenna outside



OVERVIEW OF MATCHING NETWORKS

- A matching network is connected between a source and a load, and its circuitry is usually designed such that it **transfers almost all power to the load** while presenting an input impedance that is equal to the complex conjugate of the source's output impedance (**minimize SWR**).
- Typical matching networks (referred to as “lossless” networks) use only reactive components, i.e., components that *store* energy rather than *dissipate* energy. Thus, matching networks **use capacitors and inductors**, and not resistors.
- **It is difficult to design a wideband matching network.** This is not surprising when we remember that the matching network is composed of reactive components: the impedance of inductors and capacitors is dependent on frequency; thus, changing the frequency of the signals passing through the matching network can cause it to be less effective.
- **Note that an antenna tuner is just a matching network with variable capacitors and multiple inductors.**

BLOCK DIAGRAM

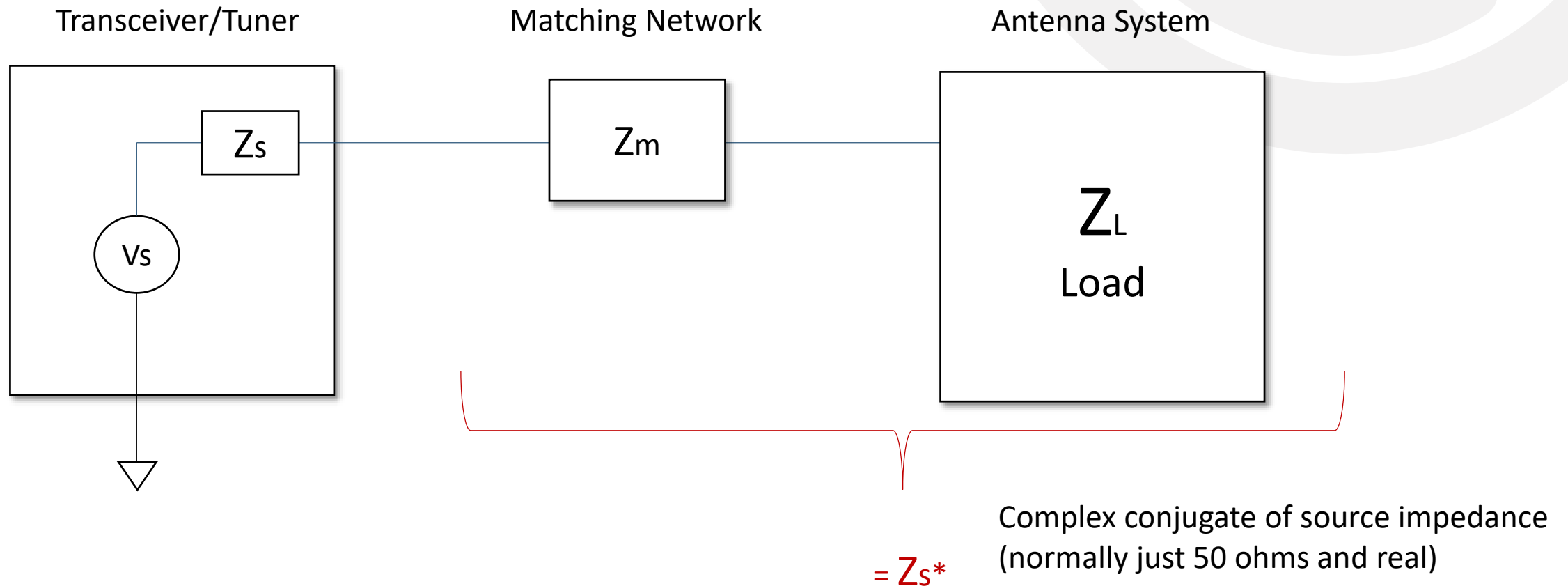

THE L NETWORK

$$Z = R + jX$$

$$X_C = -\frac{1}{2\pi fC}$$

$$X_L = 2\pi fL$$

$$j = \sqrt{-1}$$

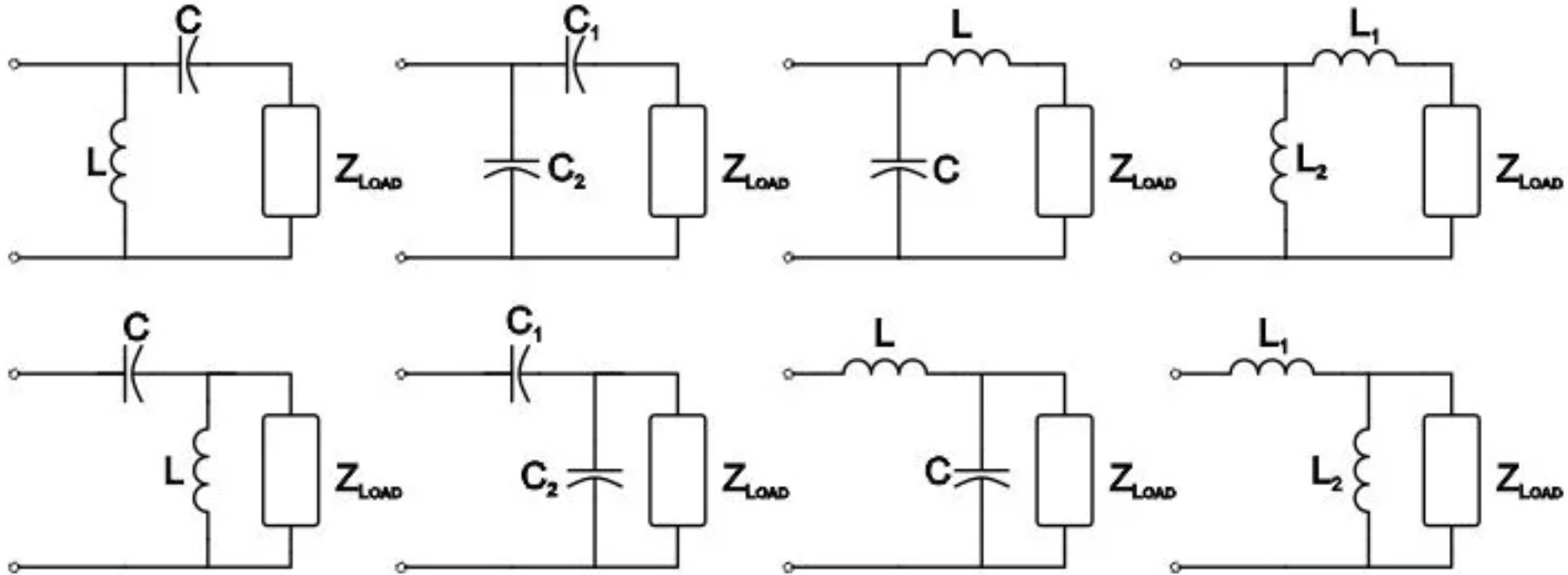

The impedance of reactive components is a function of frequency (so narrowband).

USING THE SMITH CHART

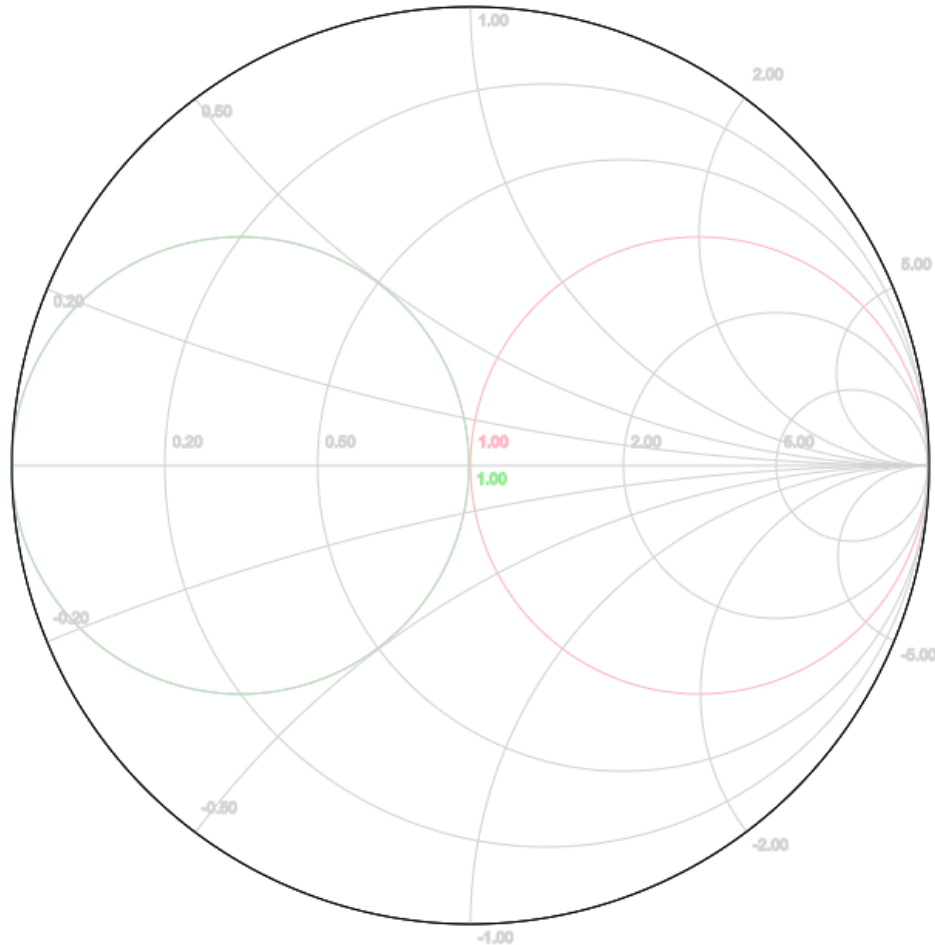

- Circles represent constant resistance
 - Perimeter circle is zero ohms
 - Red circle is 1 ohm (50 ohms normalized)
 - Arcs represent constant reactances
 - Diameter line is pure resistance (reactance is zero)
 - Arcs bending up are positive reactances (inductor)
 - Arcs bending down are negative reactances (capacitor)
-
- Load can be any point on Smith Chart
 - Want load to be at center (1.0 or 50 ohms)
 - By moving along arcs and circles, we can determine values for matching L Network that put us at 50 ohms



SMITH CHART MATCHING APP

Smith Chart Matching App | www.rfmentor.com

https://www.rfmentor.com/content/smith-chart-matching-app

Getting Started Imported Plex It! Imported (1) Imported From Fire... hose.brandmeister... www.rfmentor.com T50-2 Toroids Understanding Mat...

RF Mentor
Tools and training to help your RF/Wireless career

BESSER ASSOCIATES
The Worldwide Leader in RF and Wireless Training

Home RF Wireless Training RF/Wireless Library News

Smith Chart Matching App

Drag-n-Match Smith Chart Matching

Add Circuit Ser Cap Ser Ind Ser Res Ser TL Sht Cap Sht Ind Sht Res Sht Short TL Sht Open TL Delete Item

Note: Red is series and Green is shunt.

Add Frequency Delete Frequency 500

Zo (Ohms): 50

WIDEBAND TOROIDAL TRANSFORMERS

- Operate over very **wide frequency ranges**
- Will transform various load impedances to near 50 ohm source impedance
- **Impedance transformation is the square of the turns ratio**
- Still need a tuner to match the impedance (complex conjugate of reactance)
- Makes the tuner's job easier (less expensive tuner) or possibly eliminates need
- We will consider End-Fed Halfwave (EFHW) Antennas and Random Wire Antennas

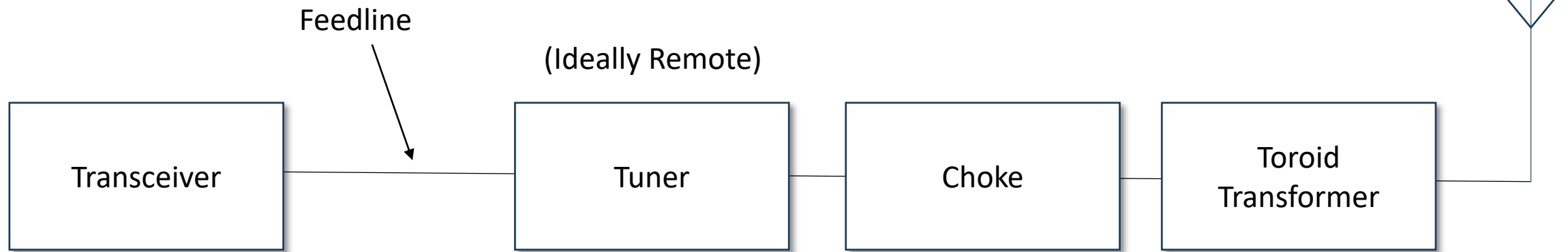

WIDEBAND TOROIDAL TRANSFORMERS

- FT240-43 Ferrite Core Toroid
- Good up to 200 watts
- For 500 watts, stack two together
- Good coverage from about 5-400 MHz
- For 80 meters, add a 100 pF 3kV high voltage capacitor to help
- Or go with FT140-43 (up to 100 watts) or -31 toroids
- Performance does depend on care in winding (even loops, no twists for multiple conductors)
- Can purchase on Amazon, Digi-Key, Mouser or kf7p.com



END-FED HALF-WAVE (EFHW) ANTENNA

- Antenna wire is tuned (cut) to the half wavelength of lowest frequency (say 80 meters)
- Will also be resonant on 40 meters and 20 meters
- The antenna generally has a high impedance (several thousand ohms) on most bands
- So an *impedance* transformation ratio of about 1:50 to 1:60 is needed to get down to 50 Ω
- This requires a *turns* ratio of about 1:7 to 1:8.

64:1 unun (unbalanced-to-unbalanced)

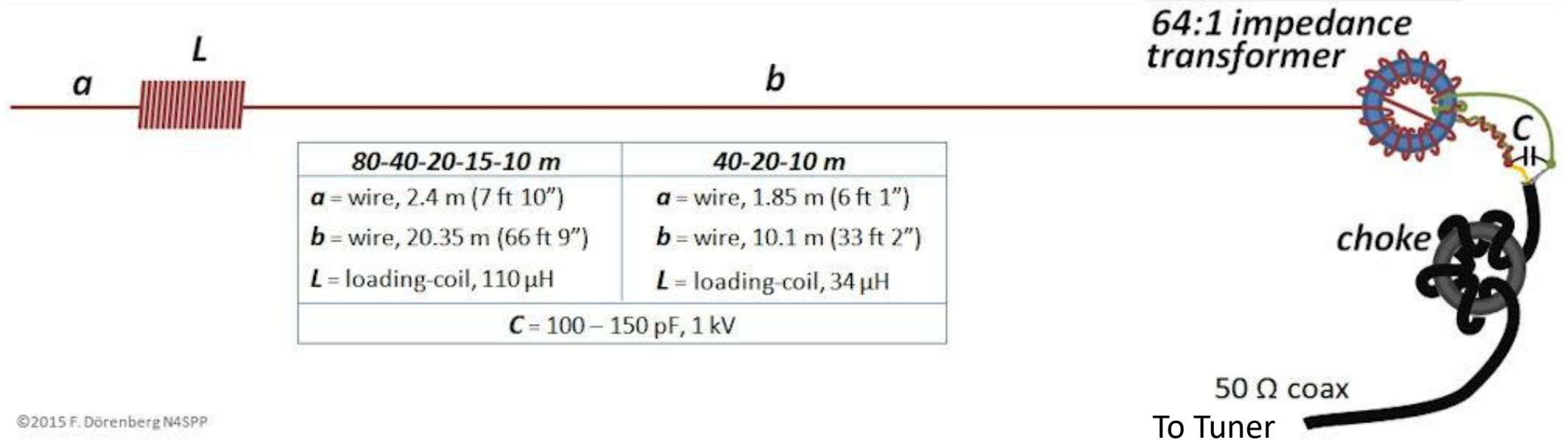

©2015 F. Dörenberg N4SPP

https://www.nonstopsystems.com/radio/frank_radio_antenna_multiband_end-fed.htm

EFHW TOROIDAL TRANSFORMER WINDING

- Use a 16:2 turns ratio (8:1)
- Impedance ratio is 64:1
- Best to twist wires together going to ground (the 2 turn section) for lower noise
- The 2-wire section is a **bifilar winding**
- Wrap the toroid in PTFE (plumber's) tape to prevent arcing if using bare or enameled copper
- Capacitor helps at 80 meters for FT240-43

1:64 transformer
for end fed antennas
3.5 - 30 MHz

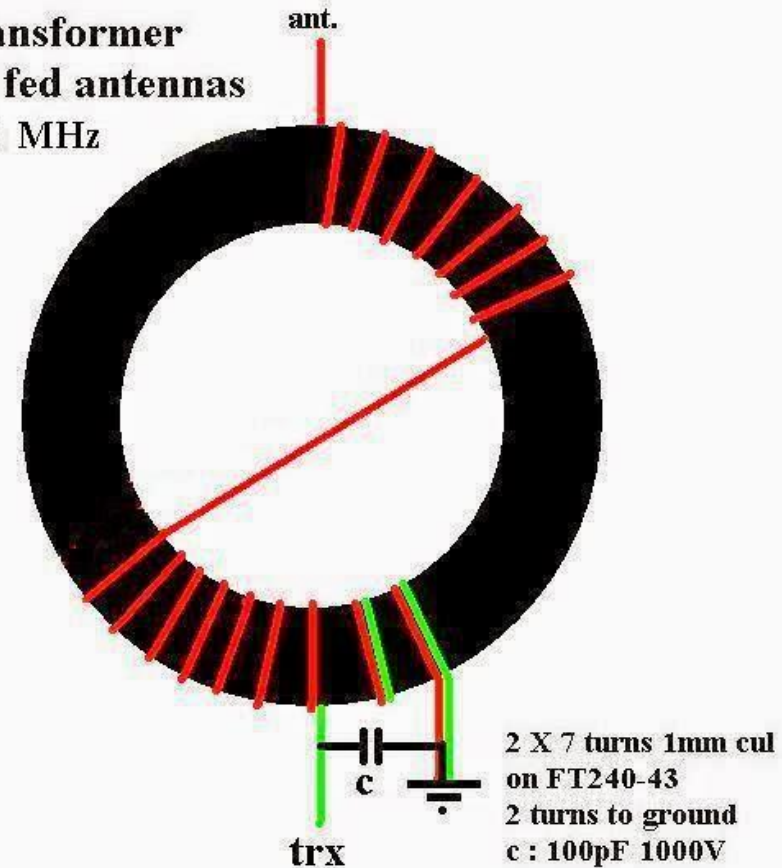



RANDOM WIRE ANTENNAS

- So-called because length is “random” and not a half-wavelength multiple
- **Avoid multiples of half-wavelength**
- There are tables of lengths to avoid and best lengths for multiple bands
- Random Wire lengths (in feet) that are not half wavelengths or multiples at any frequency from 1.8-30 MHz:

REVISED: 29 35.5 41 **53** 58 71 84 107 119 148 203 347 407 423

<http://www.hamuniverse.com/randomwireantennalengths.html>

RANDOM WIRE TRANSFORMER WINDING

9:1 unun (unbalanced-to-unbalanced)

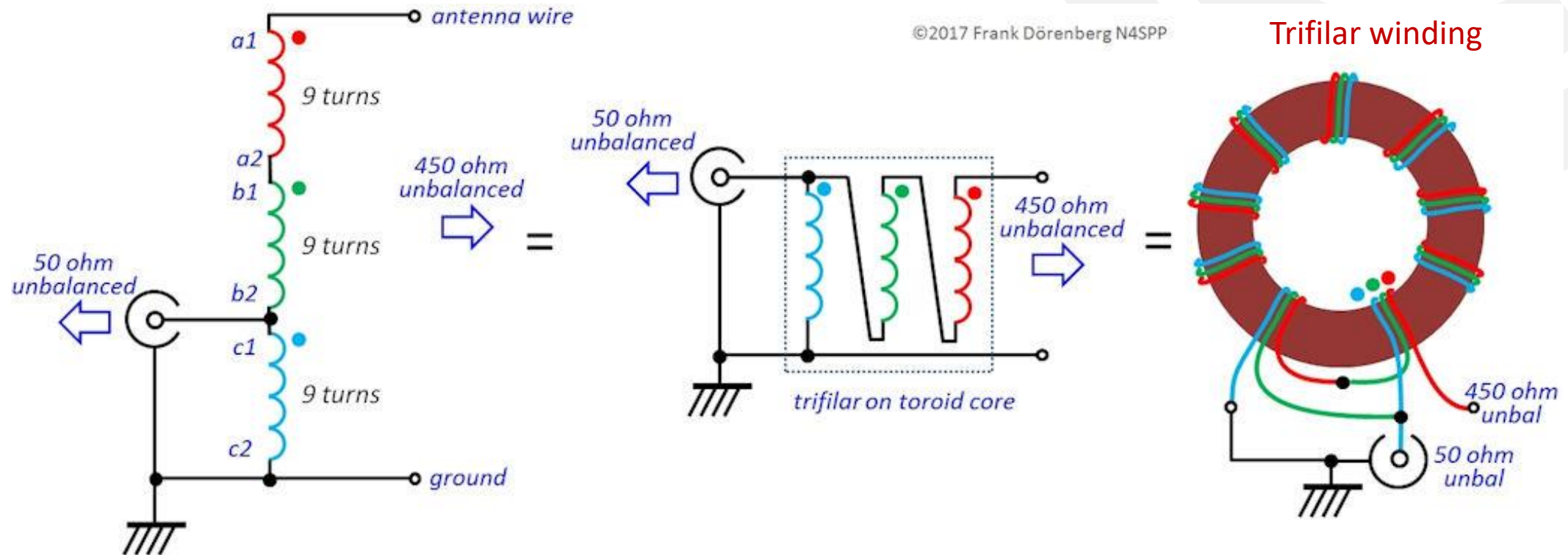

https://www.nonstopsystems.com/radio/frank_radio_antenna_multiband_end-fed.htm

WINDING THE CHOKE

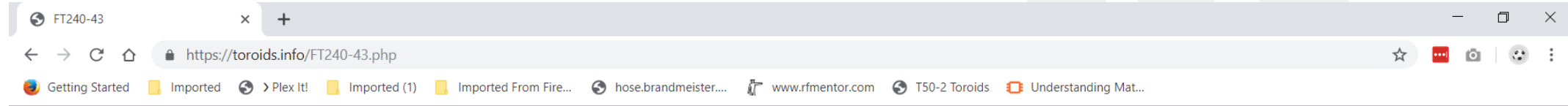

Specs for **FT240-43** RF Toroids

FB-43-101	BLN1728-8	FT23-43	FT114-43	T25-2	T80-2
FB-43-2401	BN-43-2402	FT37-43	FT114-61	T25-6	T80-6
FB-73-2401	BN-61-2402	FT37-61	FT140-43	T30-2	T80-10
FB-43-4852	BN-43-1502	FT37-67	FT140-61	T30-6	T80-17
FB-43-7351	BN-61-1502	FT50-43	FT140-77	T30-10	T94-2
FB-31-1020	BN-43-302	FT50-61	FT240-31	T37-0	T94-6
	BN-61-302	FT50-75	FT240-43	T37-1	T94-10
	BN-43-202	FT50-J	FT240-52	T37-2	T106-0
	BN-61-202	FT82-43	FT240-K	T37-6	T106-2
	BN-73-202	FT82-61	FT240-61	T37-7	T106-6
	BN-43-3312		FT290-43	T37-10	T130-0
	BN-43-7051		XXX-XX	T37-17	T130-1
	BN-61-002			T44-2	T130-2
				T44-6	T130-6
				T50-1	T130-17
				T50-2	T157-2
				T50-3	T157-17
				T50-6	T184-17
				T50-7	T200-2
				T50-10	T200-6
				T50-17	T225-2B
				T68-1	
				T68-2	
				T68-6	
				T68-7	

Physical Dimensions

OD(A) = 2.40 in / 61.0 mm +/- 1.30 mm
 ID(B) = 1.40 in / 35.55 mm +/- 0.85 mm
 Ht(C) = 0.50 in / 12.7 mm +/- 0.50 mm

$A_L = 1075 \pm 20\%$ $\mu H = (A_L * \text{Turns}^2) / 1000$
 Actual measured AL using 10 turns #28 wire

Temperature Stability (ppm /°C) = 12500

Color Code = shiny black

Application Freq Range
 Wideband Transformers 5 - 400 MHz
 Power Transformers 0.5 - 30 MHz
 RFI Suppression 5 - 500 MHz

Orders and Pricing
www.kitsandparts.com

Turns-Length Calculator for FT240-43
 Includes 1 inch / 2.5 cm pig-tails

MHz	uH	pF	ohms	turns	inches - cm	Calc	Clear
0	0	0	0	0			

enter uH to Calc number of turns, or
 enter number of turns to Calc uH, or
 enter two (2) items: MHz, uH, pF, ohms or turns to Calc all values.

ANTENNA FAR END



MATCHING NETWORK AND CHOKE

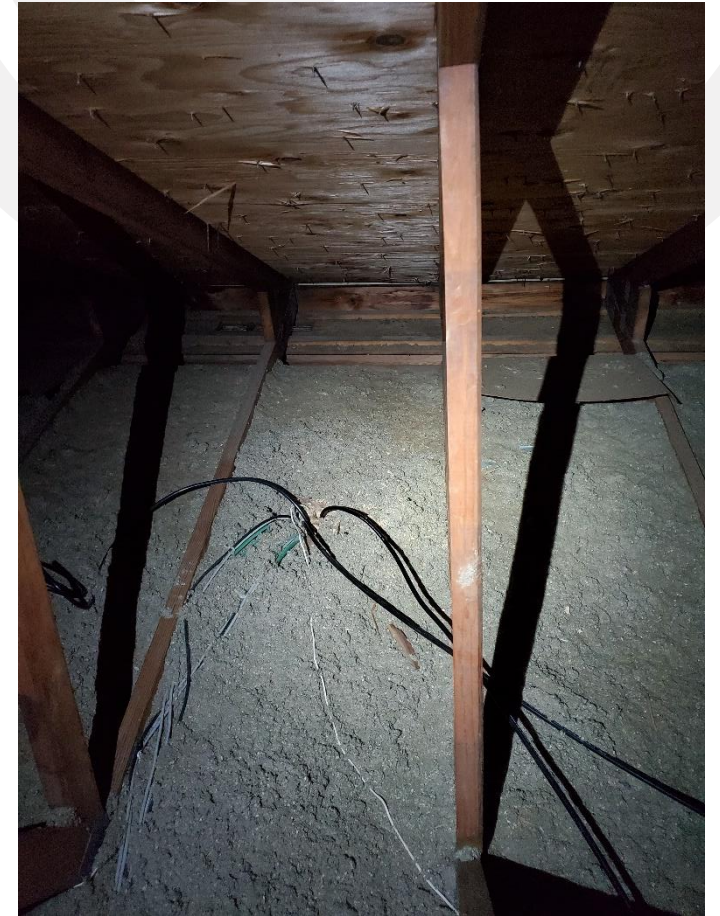
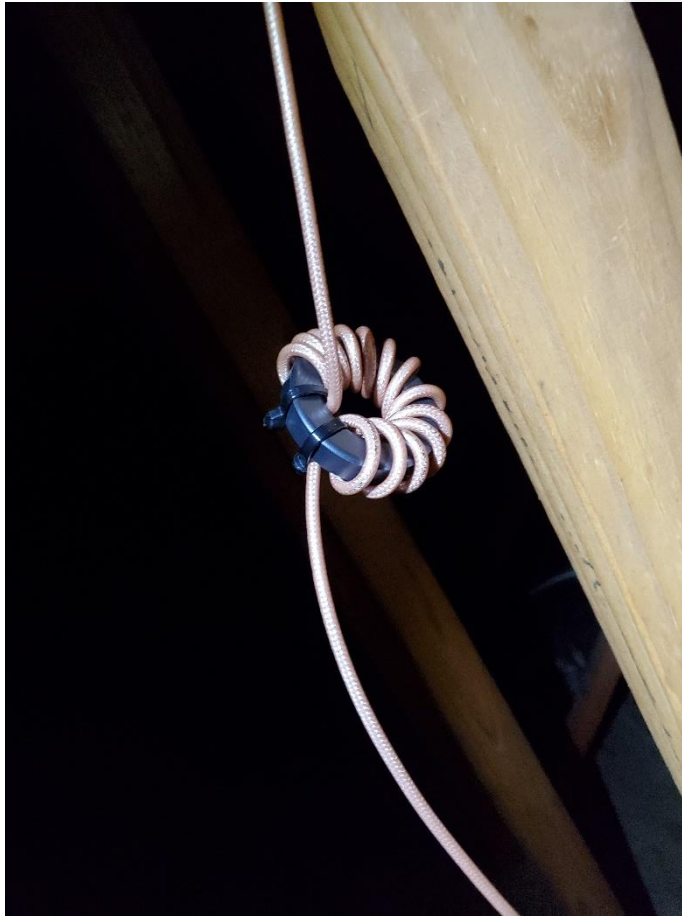
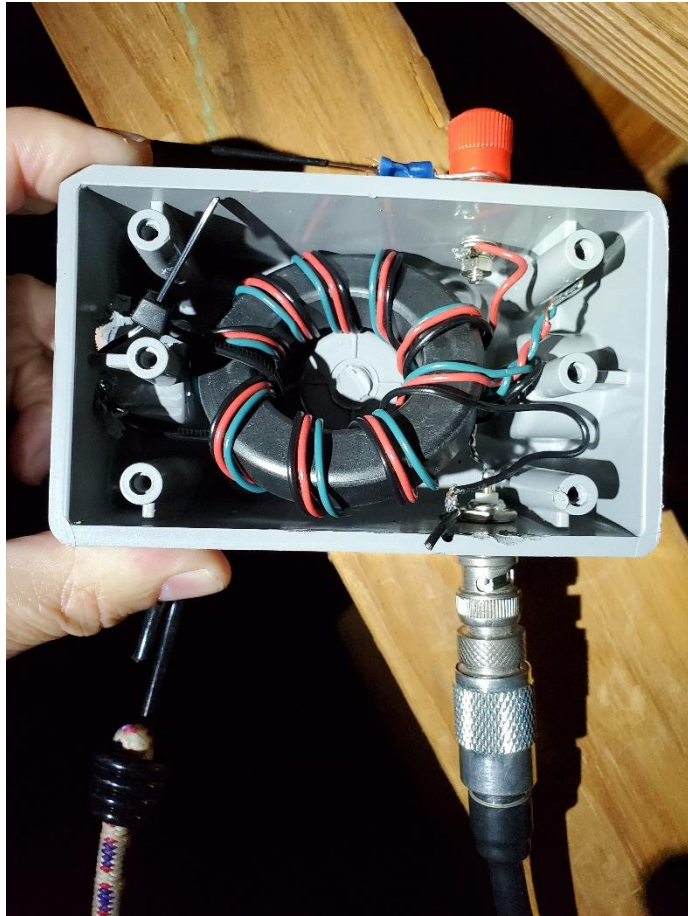

TUNER AND TRANSCEIVER



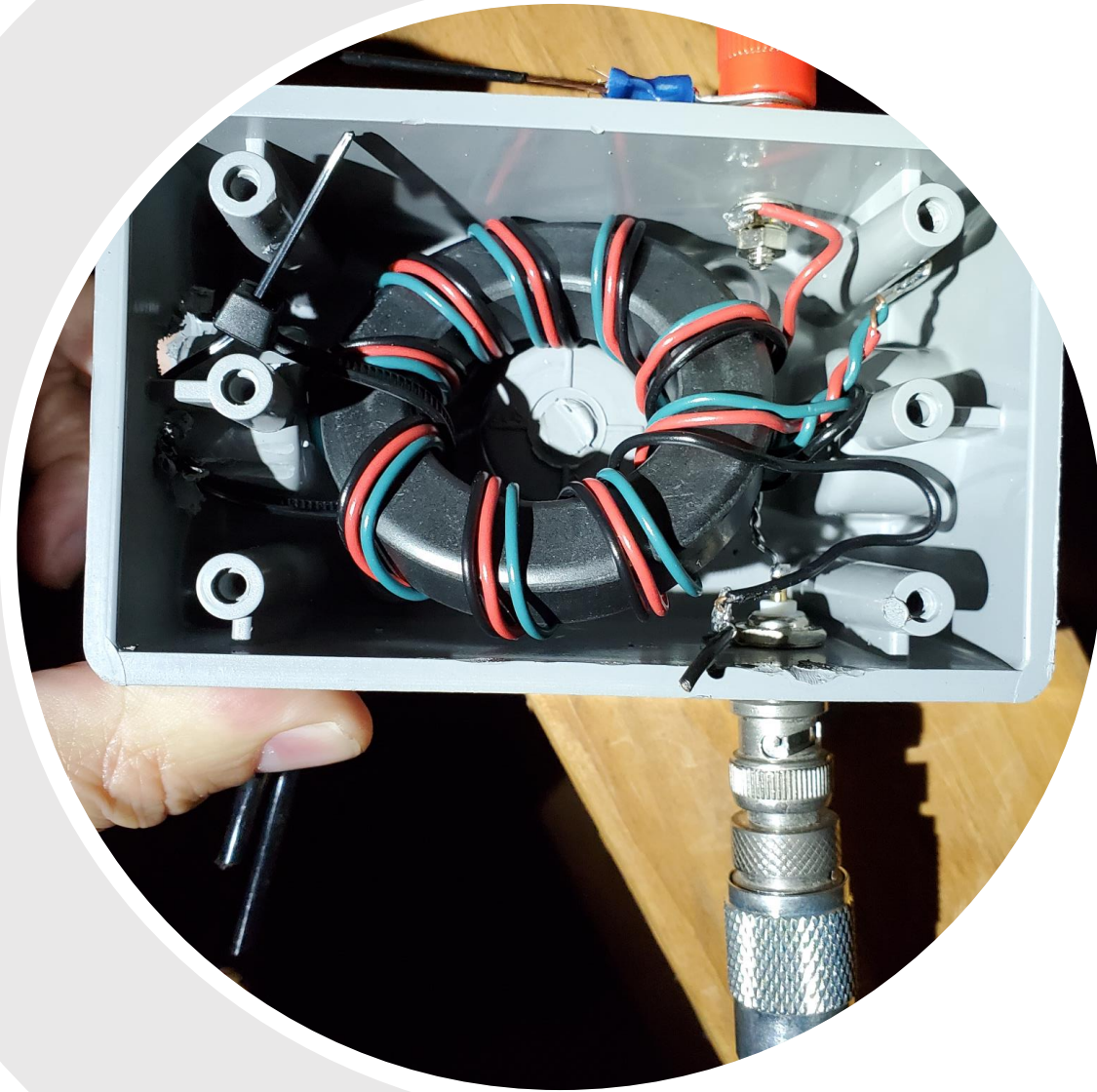

THANK YOU

 W8LRJ@ARRL.NET

 CHECK BARC WEBSITE FOR COPIES OF THIS PRESENTATION AT BELLBROOKARC.ORG