

THE ORIGINS OF RADIO[©]

Hamvention [®] 2015

Frank J. Beafore

WS8B

Forum

fo·rum (fôrm, fr-)

n. pl. fo·rums also fo·ra (fôr, fr)

* A public meeting place for open discussion.

* A medium for open discussion or voicing of ideas

* A public meeting or presentation involving a discussion usually among experts and often including audience participation.

Introduction

- This presentation is based on the landmark book Antennas by John Kraus (K8JK)
- Basic antenna physics dates back to 600 BC
- This forum subject will concentrate on the time period between 1600 to 1900
- Participants are encouraged to engage in a healthy dialog during the presentation

Radio

- Radio Defined:

Radio

- Radio Defined:
- A combination of electromagnetic and electrostatic waves used to form a communicat



Fundamental Components of a Radio System

A decorative horizontal bar consisting of a dark blue segment on the left and a lighter blue segment on the right, spanning the width of the slide.

Fundamental Components of a Radio System

- Antenna

Fundamental Components of a Radio System

- Antenna
- Feed line

Fundamental Components of a Radio System

- Antenna
- Feed line
- Receiver

Fundamental Components of a Radio System

- Antenna
- Feed line
- Receiver
- Transmitter

Fundamental Components of a Radio System

- Antenna
- Feed line
- Receiver
- Transmitter
- Feed line

Fundamental Components of a Radio System

- Antenna
- Feed line
- Receiver
- Transmitter
- Antenna



Question?

Question

- How many radios are in today's automobiles?

Answer:

- Many-
 - AM/FM Radio
 - Satellite Receiver
 - Remote door opener
 - Remote starter
 - Garage opener
 - Tire Pressure Sensors
 - Toll Booth Counters
 - Gate Openers
 - Cell Phone
 - Blue Tooth
 - GPS
 - Wi-Fi
 - Cell Phone Transceiver

Last Question

- Who invented radio?

Lets get started

Remember the definition of radio -.....

.....A combination of electromagnetic and electrostatic waves used to form a communication

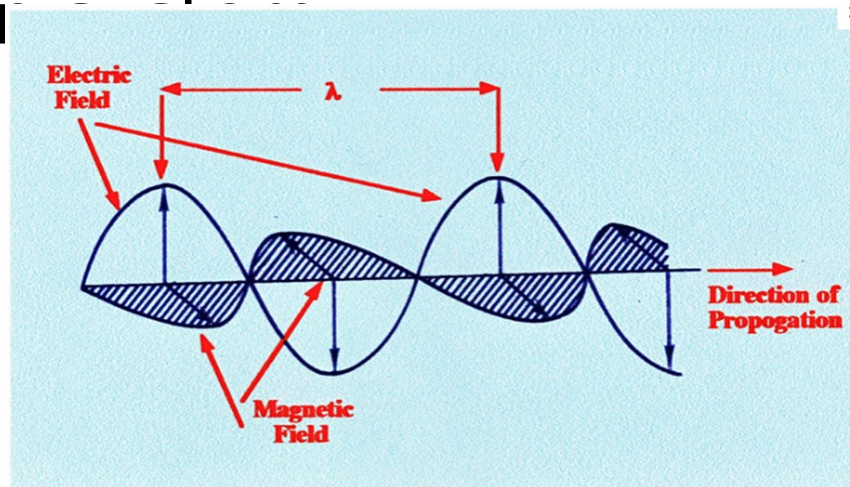

Radio Wave Components

- Electromagnetic Wave
- Electrostatic Wave
- Both 90 degrees apart

Thales of Miletus

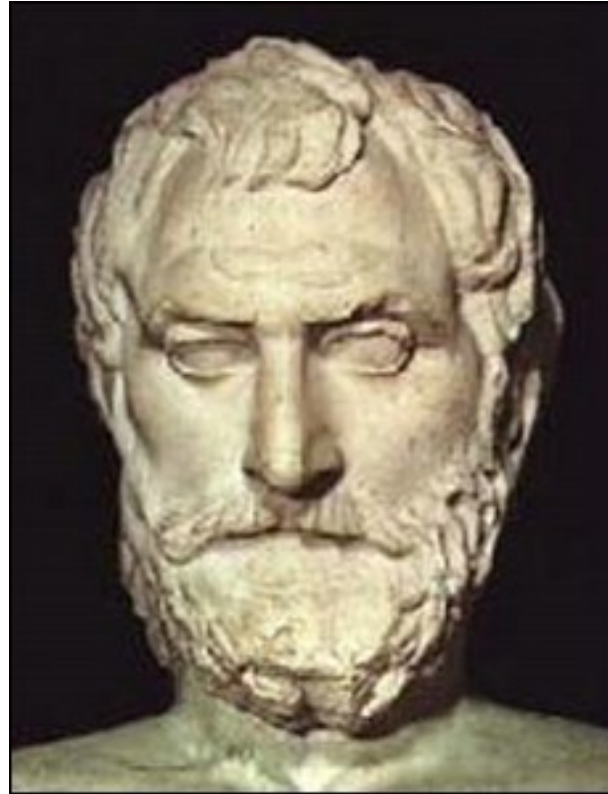

600 BC

Thales of Miletus
(Θαλῆς ὁ Μιλήσιος)

Electrostatic

600 BC a Greek mathematician named Thales of Miletus noted that when amber was rubbed with silk it produced sparks. The Greek word for amber was **elektron**.



Electromagnetic

Thales also noted the attractive power between pieces of loadstone. The loadstone was found at a place called **Magnesia**



William Gilbert – 1600



On the Magnet and Magnetic Bodies, and on the Great Magnet the Earth

Gilbert: the CGS unit of magnetomotive force

Benjamin Franklin - 1750

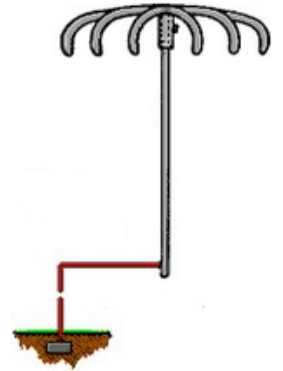
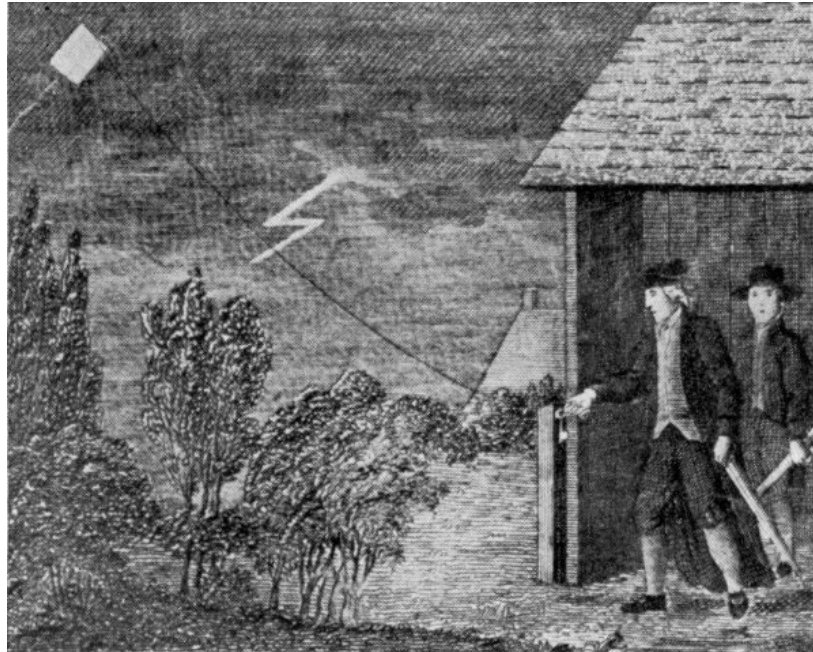
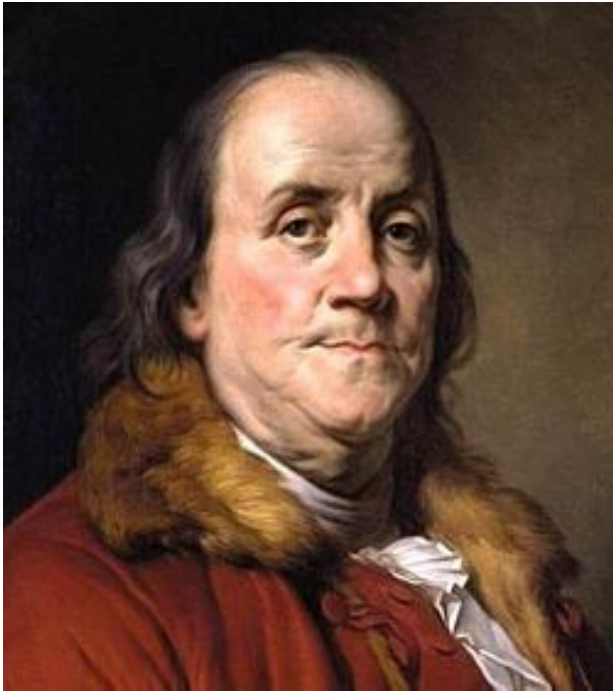

...established the law of conservation of charge - positive and negative

Charles Agustin de Coulomb

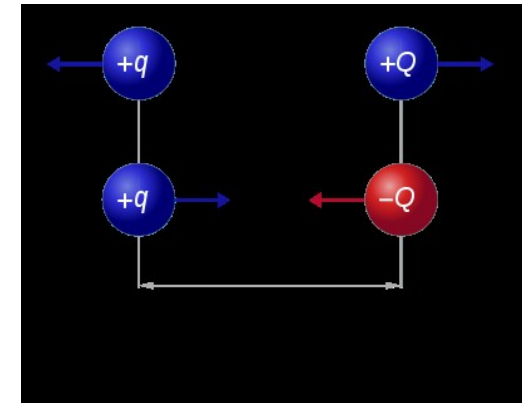
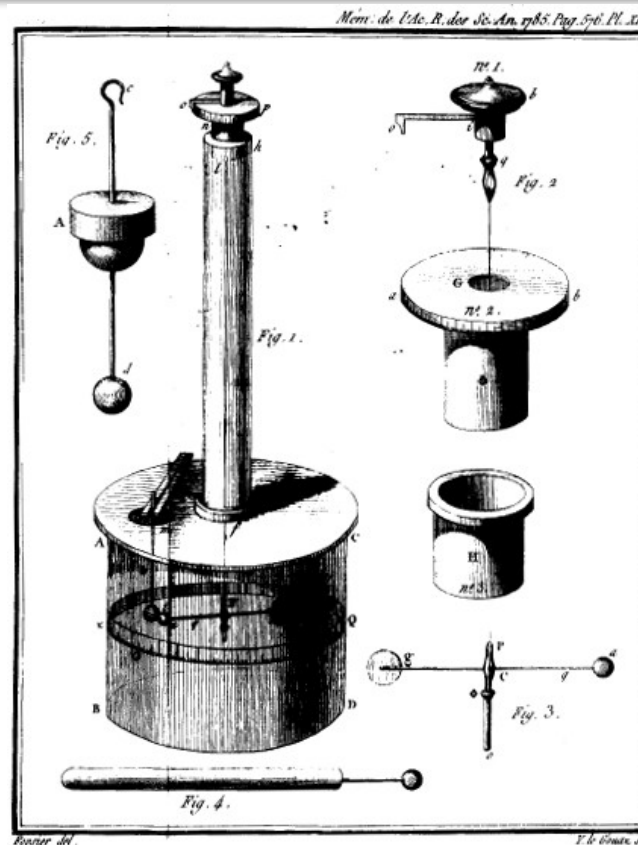

Measured
electromagnetic forces

Coulomb (symbol: C) is the derived unit of electric charge.

Karl Friedrich Gauss



Gauss: a unit of measurement of a magnetic field

Luigi Galvani

Used Coulomb and Gauss' discoveries to invent the galvanometer

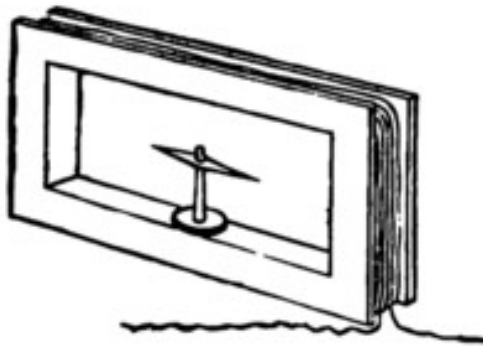

galvanometer



The first "multimeter"



Note the Frog Legs

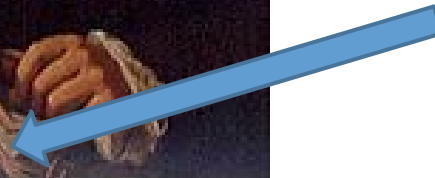

Alessandro Volta

SI derived unit for electric potential, electric potential difference, and electromotive force



Alessandro Volta

SI derived unit for electric potential,
electric potential difference, and
electromotive force



Alessandro Giuseppe Antonio Anastasio Gerolamo Umberto
Volta

Alessandro Volta

SI derived unit for electric potential,
electric potential difference, and
electromotive force



Alessandro Giuseppe Antonio Anastasio Gerolamo Umberto
Volta
(Alice-Joe-Tony-Andy-Jerry-Robert-Volt Aka: Eveready
Bunny)

Volta

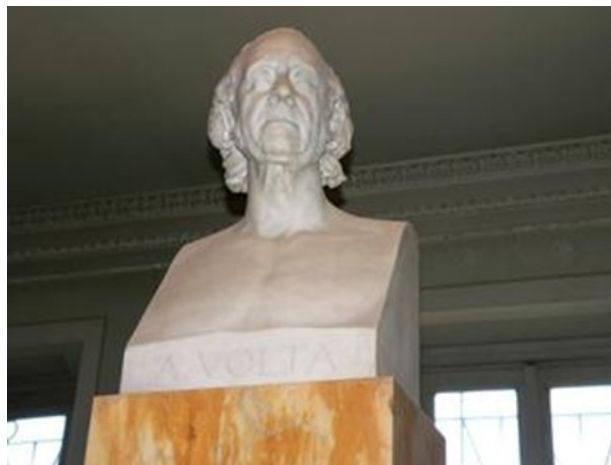

Volta



Volta



Volta



Frog Legs Again !

Volta



Volta

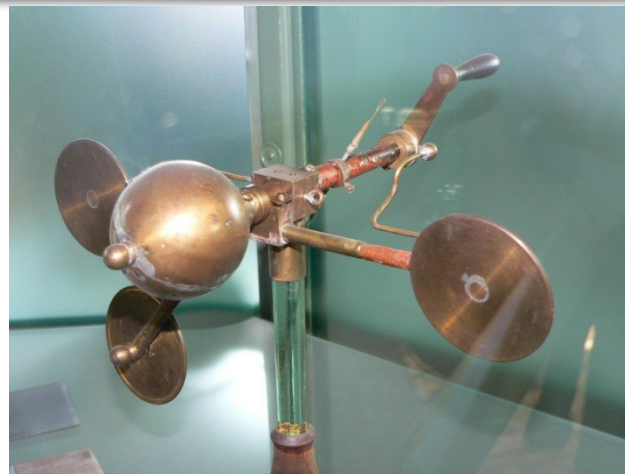
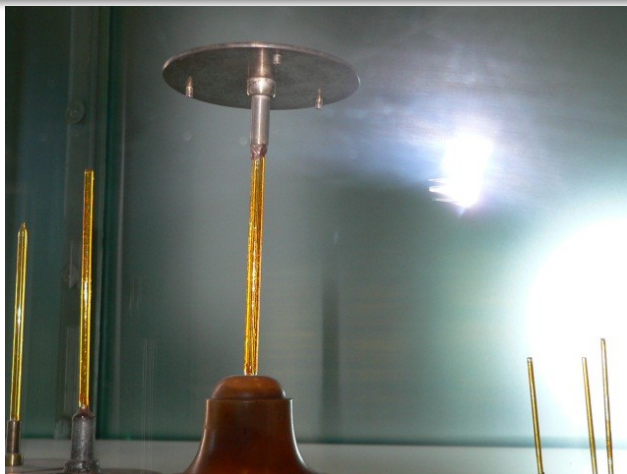

Hans Christian Oersted

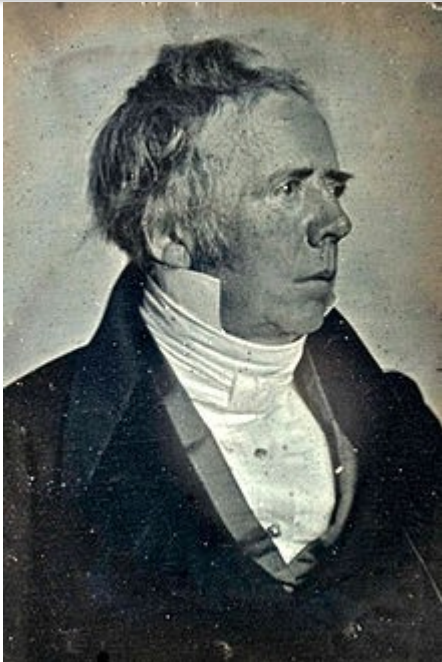

Discovered that a current carrying wire would move a compass needle

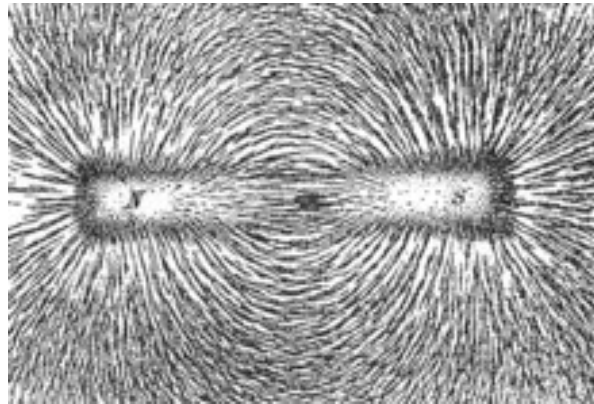

A unit of magnetizing field (also known as H-field, magnetic field strength or intensity) in the CGS system of units

Andre' Marue Ampere

Extending Oersted's observations he invented the solenoid coil – the basis for the first telegraph sounder.



Amp: SI unit of electric current

Georg Simon Ohm

Published what is now known as Ohm's law.

$$V(e) = IR$$



[Ohm: SI unit of electrical resistance](#)

James Watt

$$P = EI$$

Watts = Volta x Ampere



the SI unit of power, the watt, was named after him

Michael Faraday



Faraday Cage

Backwards from Oersted's discovery ...
.... changing magnetic field can produce electricity.

1 Faraday = 96 485.3415 coulombs

Joseph Henry



Observed and confirmed Faraday's discoveries.

[Henry: SI unit of inductance](#)

James Clark Maxwell

Founded the science of electromagnetics.....

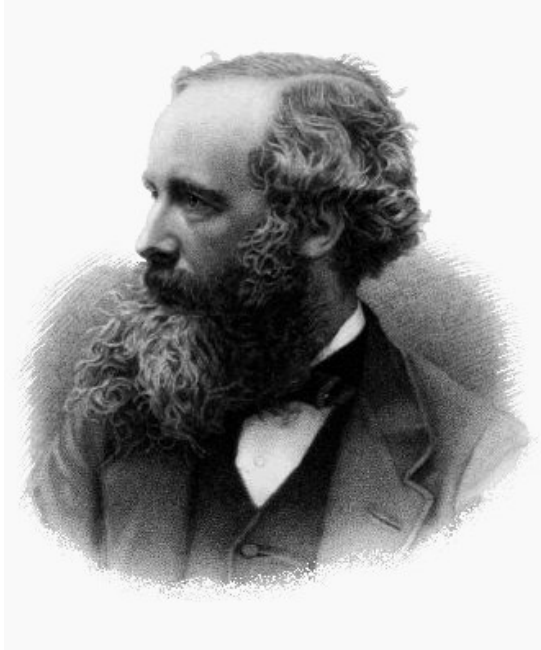

$$\oint \mathbf{E} \cdot d\mathbf{A} = \frac{q_{enc}}{\epsilon_0}$$

$$\oint \mathbf{B} \cdot d\mathbf{A} = 0$$

$$\oint \mathbf{E} \cdot d\mathbf{s} = -\frac{d\Phi_B}{dt}$$

$$\oint \mathbf{B} \cdot d\mathbf{s} = \mu_0 \epsilon_0 \frac{d\Phi_E}{dt} + \mu_0 i_{enc}$$

Maxwell: A CGS unit measuring magnetic flux.

Heinrich Rudolph Hertz

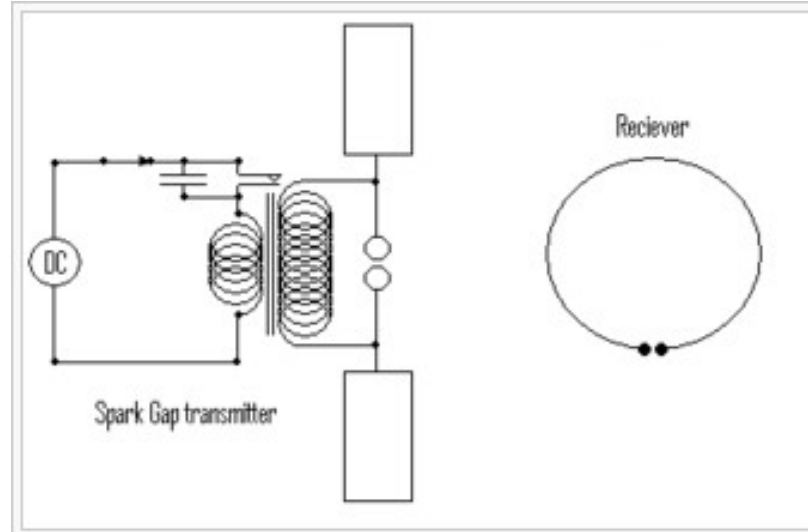

First Spark Gap Transmitter

Hertz: The SI unit hertz (Hz) was established in his honor by the IEC in 1930 for frequency (Cycles per Second)

Édouard Branly

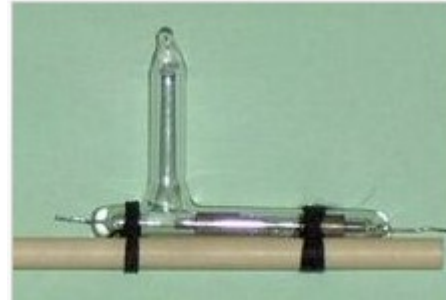

The coherer was a primitive form of radio signal detector used in the first radio receivers

Guglielmo Marconi

Moved Hertz's experiments from the laboratory to actual use as a communication system



Marconi is known as the father of long distance radio transmission

Guglielmo Marconi

Moved Hertz's experiments from the laboratory to actual use as a communication system

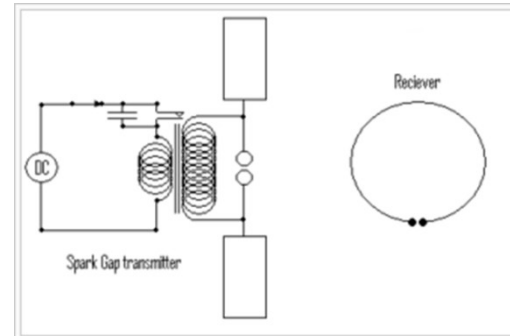

known as the father of long distance radio transmission

Guglielmo Marconi

Moved Hertz's experiments from the laboratory to actual use as a communication system

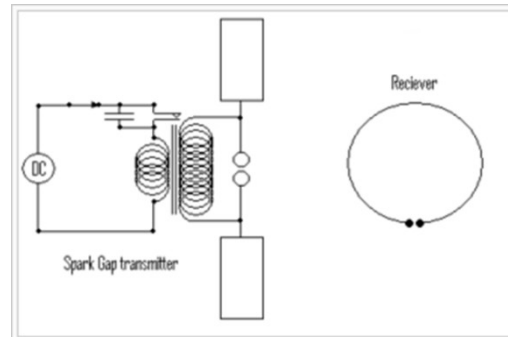

Guglielmo Marconi

Moved Hertz's experiments from the laboratory to actual use as a communication system

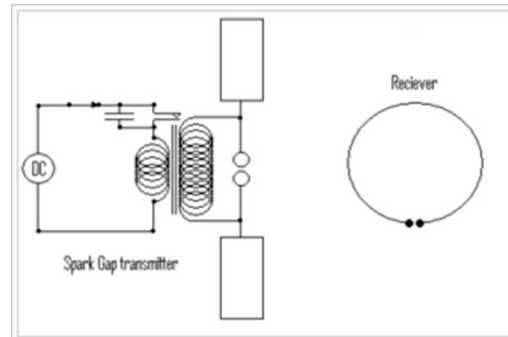

Charles Protius Steinmetz and Alexander Gram Bell

ed the American Institute of Electrical Engineers to recognize Marconi's invention



Steinmetz

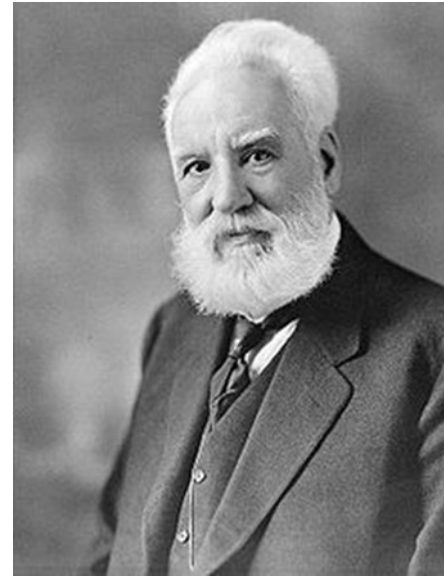

Bell

Thomas A. Edison

Inventions that contributed to the use of radio.

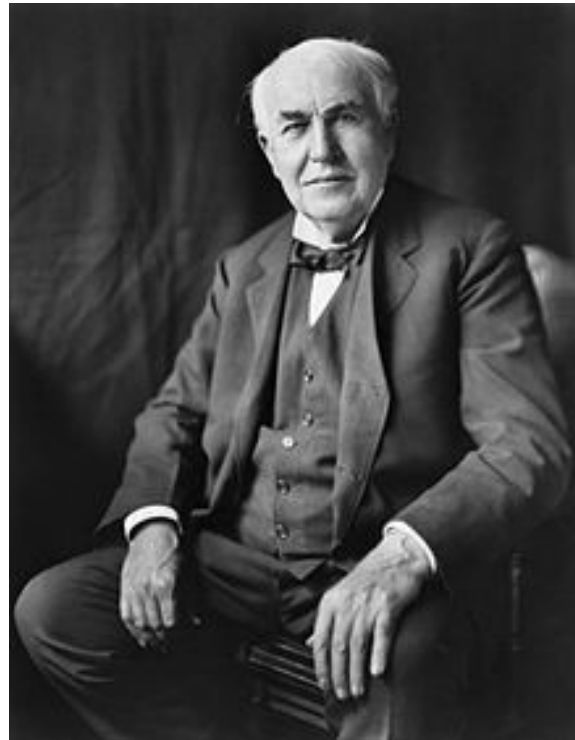

Robert J. VanDe Graff



The "Static Man"

The Electromagnetic Show Boat

Nikola tesla

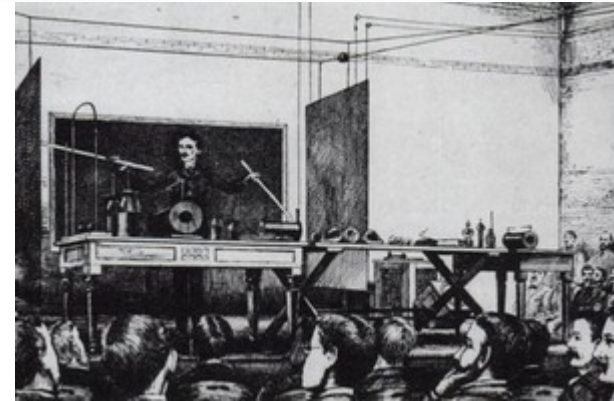
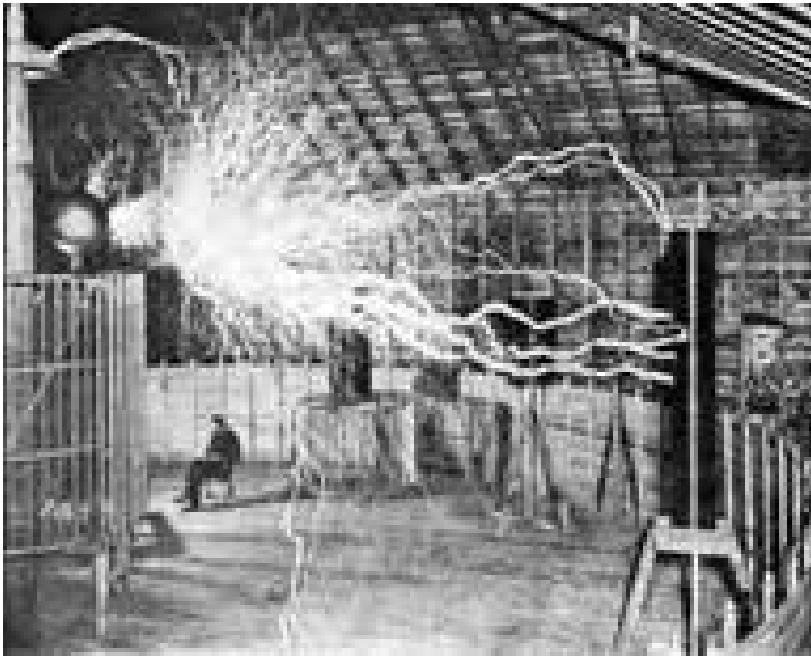

Tesla demonstrating wireless transmissions during his high frequency and potential lecture of 1891. After continued research, Tesla presented the fundamentals of radio in 1893.



.../ ./ --/ --././.-.../ / ..-//-..../ /--/---/./-.../.



Samuel F.B. Morse



Jagadis Chandra Bose

Discovered that shorter wave lengths can be used for radio communications

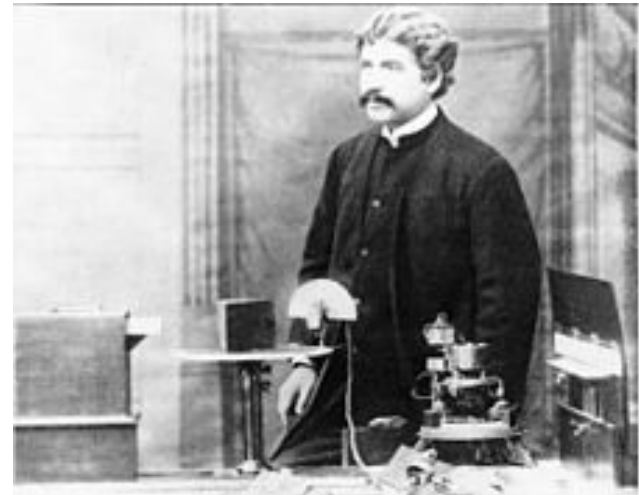

Bose's 60 GHz microwave apparatus at the Bose Institute, Kolkata, India. His receiver (*left*) used a galena [crystal detector](#) inside a horn antenna and galvanometer to detect microwaves. Bose invented the crystal radio detector, waveguide, horn antenna, and other apparatus used at microwave frequencies

Fleming Valve



No. 603,684. PATENTED NOV. 7, 1905.

J. A. FLEMING.
INSTRUMENT FOR CONVERTING ALTERNATING ELECTRIC CURRENTS
INTO CONTINUOUS CURRENTS.
APPLICATION FILED APR. 10, 1904.

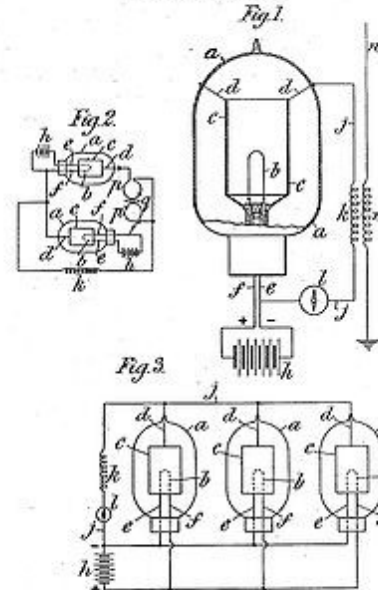

Witnesses
William H. Davis.
James J. Rogers.

Inventor
John Ambrose Fleming
by his attorney
Russell M. Stoddard

Invented the electron tube that permitted controlled oscillation, detection and amplification

Lee De Forest

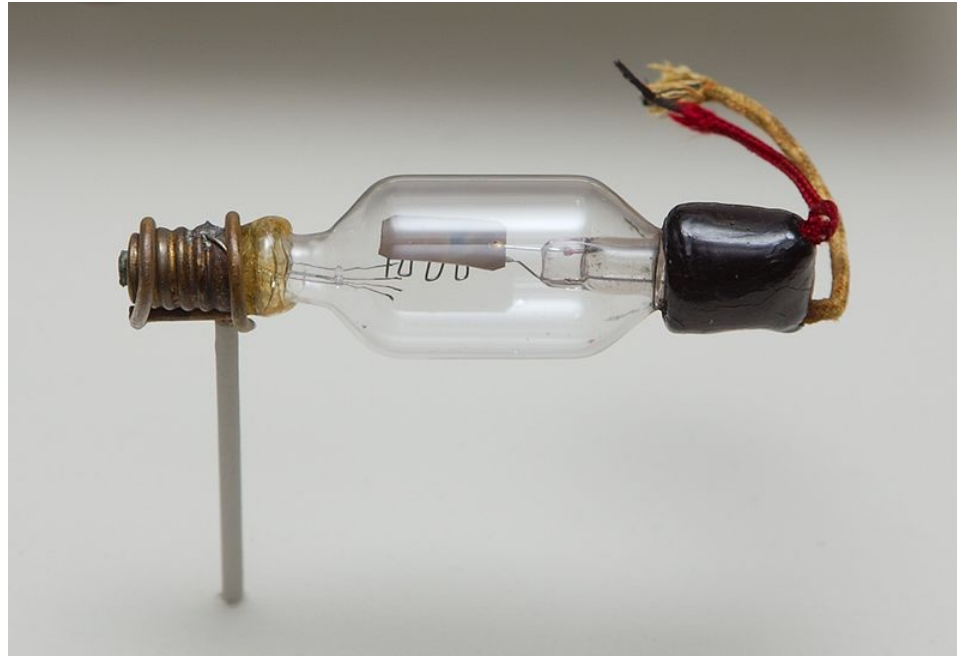

Continued the refinement of the electron tube.

H.P. Maxum



American Radio Relay League Station 1AW
Hiram Percy Maxim, Owner 276 No. Whitney Street, Hartford, Conn.
Radio Y-904 1-29-25

Your..... signals were worked here on..... at about
heard

A.M. E.S.T.
P.M.

on Tuska three-circuit tuner and two stages audio amplification, Baldwin phones.
Audibility.....

Remarks: *The Q.S.K. your card I read on 83 meters and I am a lot of fun to get to be getting on.*

Wave-length.....
QRM.....
QRN.....
QSS.....
Weather.....
Tone.....
Wave.....

1AW

Would like report on 1AW's signals if you hear them. Best 73's.
Hiram Percy Maxim Operator

He created the [ARRL](#) in 1914 as a response to the lack of an organized group of "relay" stations to pass messages via amateur radio. Relaying messages allowed them to travel farther than any single station's reach at the time.

Paul Godley

- In 1921, the ARRL sent Paul Godley to Scotland to try to receive a Greenwich Connecticut signal on 200 meters. The transmitter was invented by F H

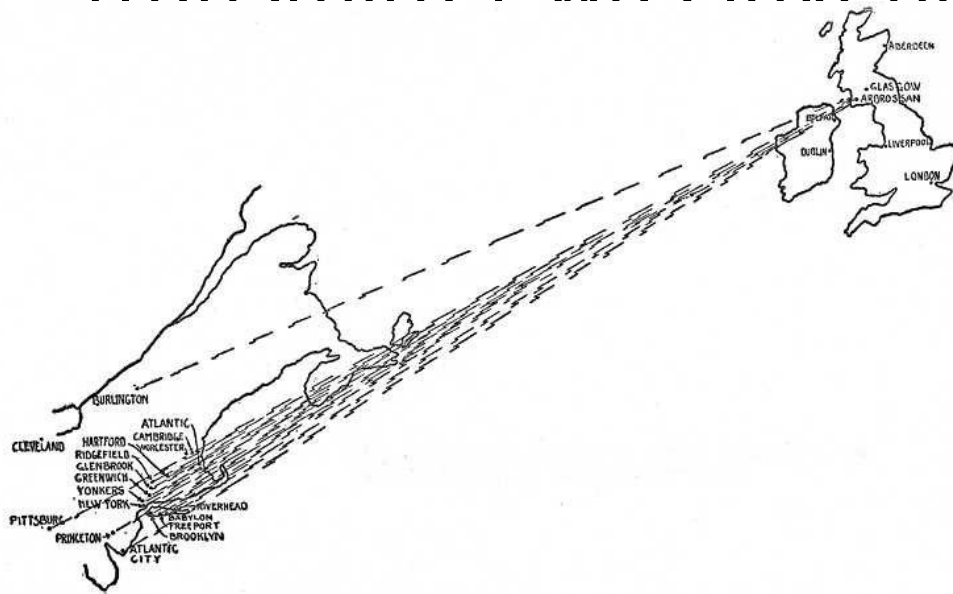

Karl Guthe Jansky



Studied thunderstorms and other forms of static and discovered that radio waves are directional. He also discovered that a lot of atmospheric static actually emanated from the sun.

Colepitts

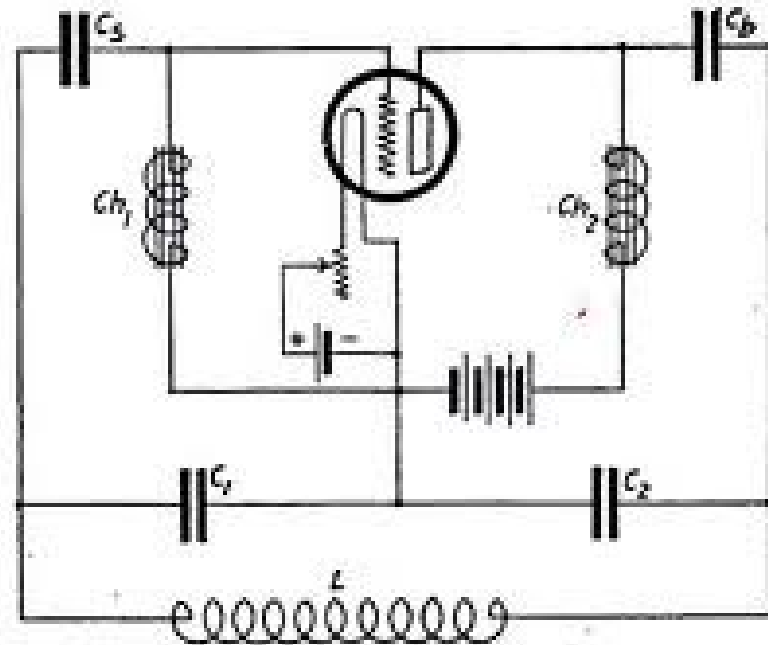
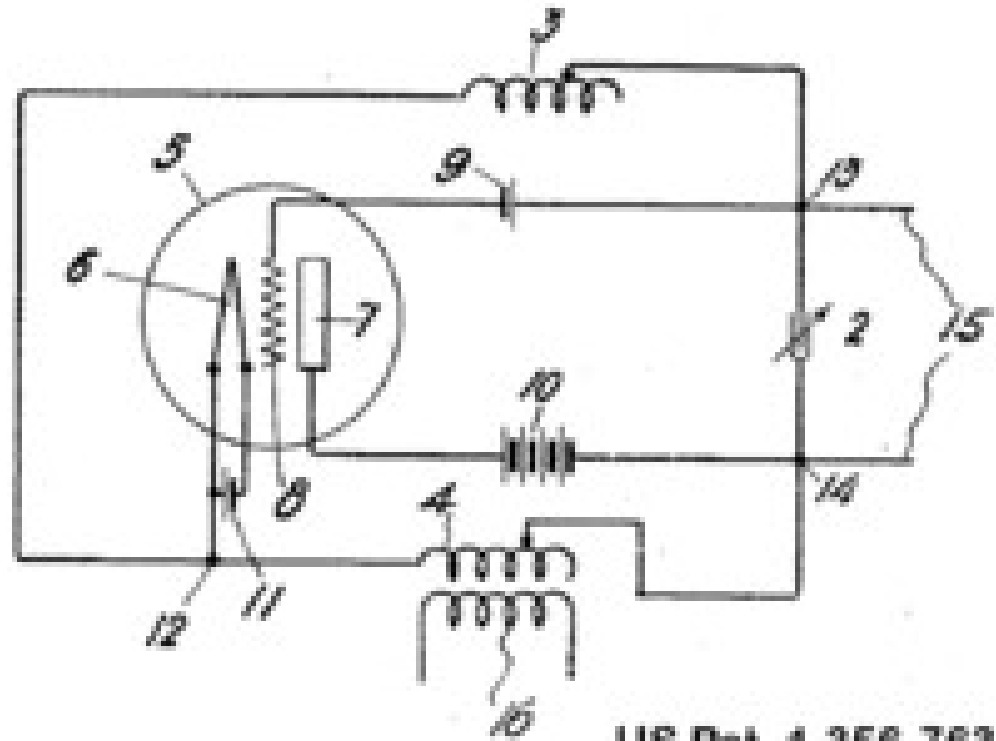

Fig. 1. The Colpitts Oscillator in a typical configuration. (From H. J. van der Bijl, *The Thermionic Vacuum Tube and Its Applications*. New York: McGraw-Hill, 1920.)

Ralph Hartley



US Pat. 1,356,763

Edwin H. Armstrong



EDWIN H. ARMSTRONG
1890 - 1954

THE ORIGINAL DRAWING OF THE FEED-BACK CIRCUIT WHICH
LARGELY DETERMINED THE COURT IN ARMSTRONG'S FAVOR

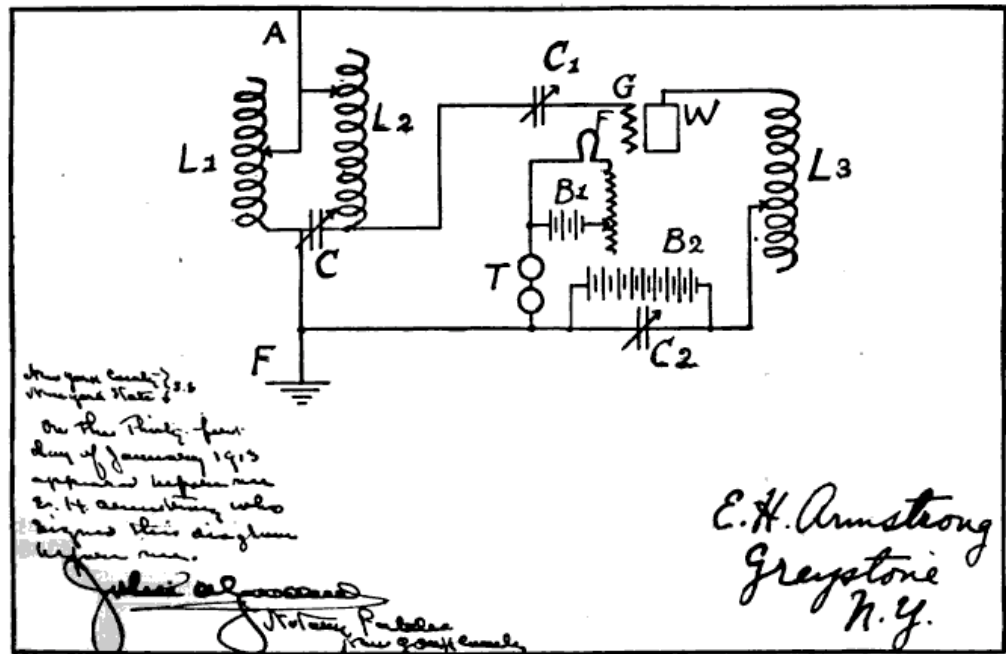

*Am you ready?
Am you ready?
On the 14th day
of January 1915
appeared before me
E. H. Armstrong who
signed this diagram
before me.*

*Julius J. [Signature]
Notary Public
New York County*

*E. H. Armstrong
Greystone
N. Y.*

Yagi-Uda

- Hidetsugu Yagi
- Shintaro Uda



Fig. 1. Shintaro Uda. (Courtesy of Library of Tohoku University, Sendai, Japan.)

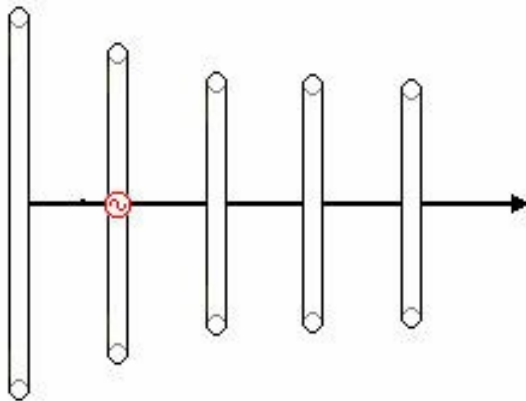

The Helical



John D. Kraus



FILE PHOTO

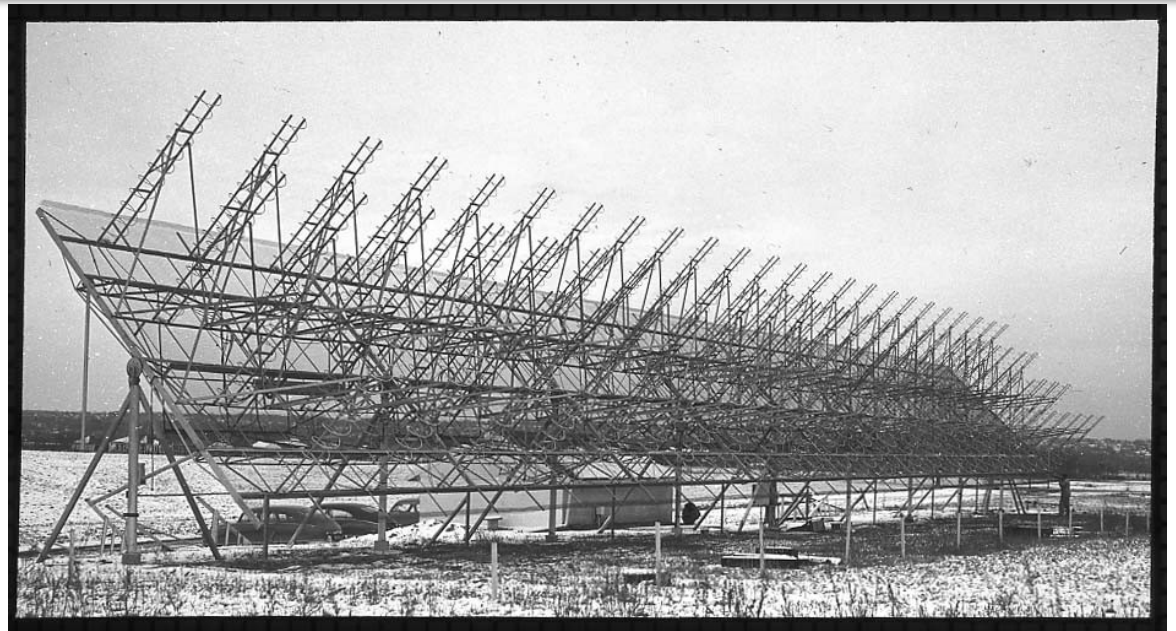

W8JK

So.....Who invented Radio?

So.....Who invented Radio?

- Gilbert
- Franklin
- Coulomb
- Gauss
- Galvani
- Volta
- Oersted
- Ampere
- Ohm
- Tesla
- Morse
- Bose
- Fleming
- DeForest
- Maxum
- Kraus
- Yagi
- Faraday
- Henry
- Maxwell
- Hertz
- Branly
- Marconi
- Steinmetz
- Bell
- Edison
- VanDeGraff
- Godley
- Jansky
- Colepits
- Hartley
- Armstrong
- Uda

Or Was it....

.....Thales

It could be you...



Questions Please

?

Thank YOU

WS8B